

SPECIFICATIONS

DIAMETER:	8" (203.2 MM)
SENSITIVITY (2.83 V @ 1 m):	90 dB
POWER HANDLING:	200 W _{RMS}
FREQUENCY RESPONSE:	20 ~ 600 Hz
NOMINAL IMPEDANCE:	4 OHMS
VOICE-COIL DIAMETER:	1.5" (38.6 MM)
DIMENSIONS:	

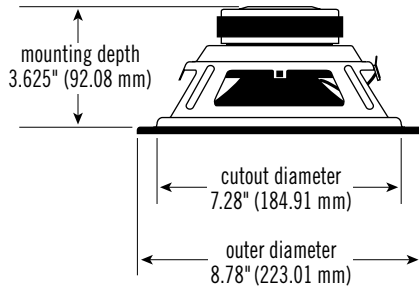

THIELE-SMALL PARAMETERS

VOICE COIL DC RESISTANCE:	R_{EVC} (OHMS)	2.90
VOICE COIL INDUCTANCE @ 1 KHZ:	L_{EVC} (MH)	3.70
DRIVER RADIATING AREA:	S_D (IN ²)	33.33
	S_D (CM ²)	216.00
MOTOR FORCE FACTOR:	BL (TM)	9.09
COMPLIANCE VOLUME:	V_{AS} (FT ³)	1.43
	V_{AS} (LITERS)	33.72
SUSPENSION COMPLIANCE:	C_{MS} (µM/N)	509.00
MOVING MASS, AIR LOAD:	M_{MS} (GRAMS)	49.68
MOVING MASS, DIAPHRAGM:	M_{MD} (GRAMS)	47.85
FREE-AIR RESONANCE:	F_S (HZ)	31.65
MECHANICAL Q:	Q_{MS}	6.80
	Q_{ES}	0.35
ELECTRICAL Q:	Q_{TS}	0.33
	Q_{ES}	0.35
TOTAL Q:	Q_{TS}	0.33
MAGNETIC-GAP HEIGHT:	H_{AG} (IN)	0.31
	H_{AG} (MM)	8.00
VOICE-COIL HEIGHT:	H_{VC} (IN)	1.06
	H_{VC} (MM)	27.00
MAXIMUM EXCURSION:	X_{MAX} (IN)	0.37
	X_{MAX} (MM)	9.50

IMPEDANCE CURVE

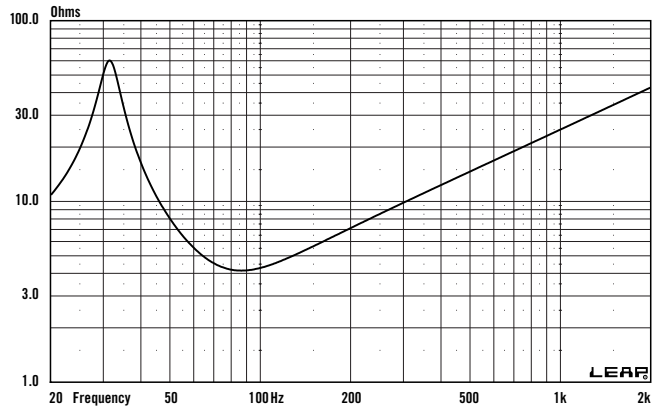

INFINITE Baffle FREQUENCY RESPONSE @ 2.83 V

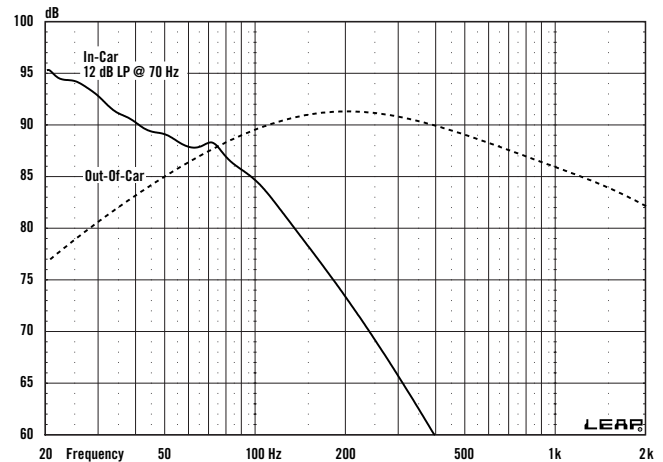

INFINITE Baffle EXCURSION/GROUP DELAY @ 100 W

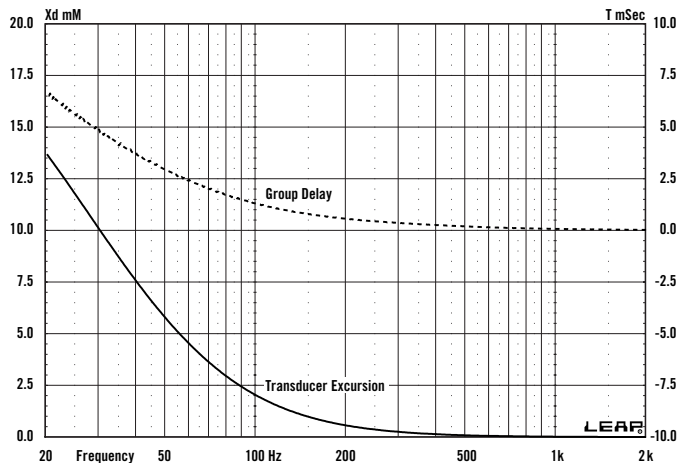

SEALED BOX VOLUME

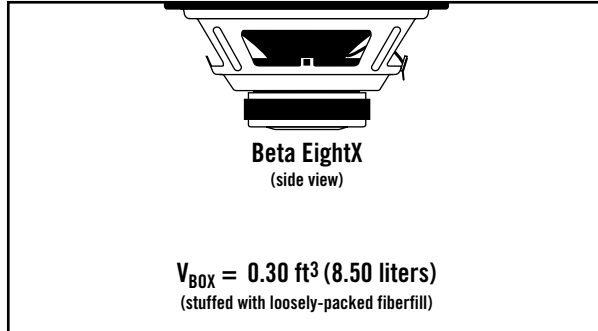

VENTED BOX VOLUME

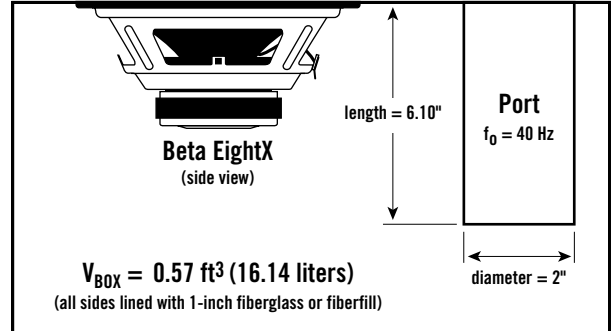

SEALED FREQUENCY RESPONSE @ 2.83 V

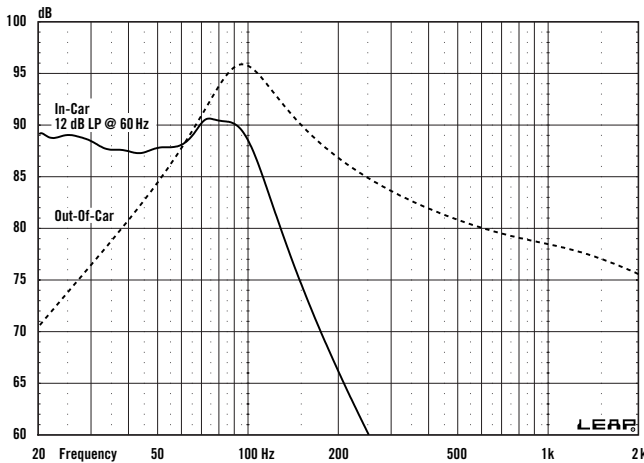

VENTED FREQUENCY RESPONSE @ 2.83 V

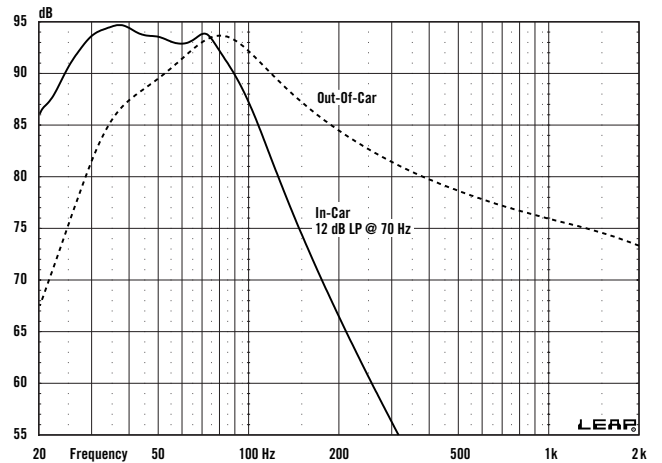

SEALED EXCURSION/GROUP DELAY @ 200 W

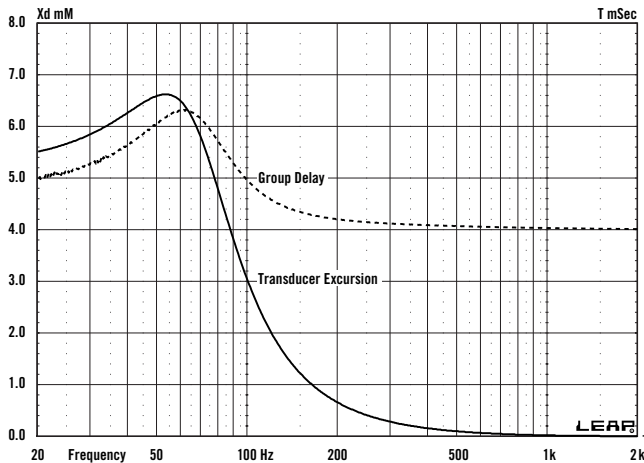

VENTED EXCURSION/GROUP DELAY @ 250 W

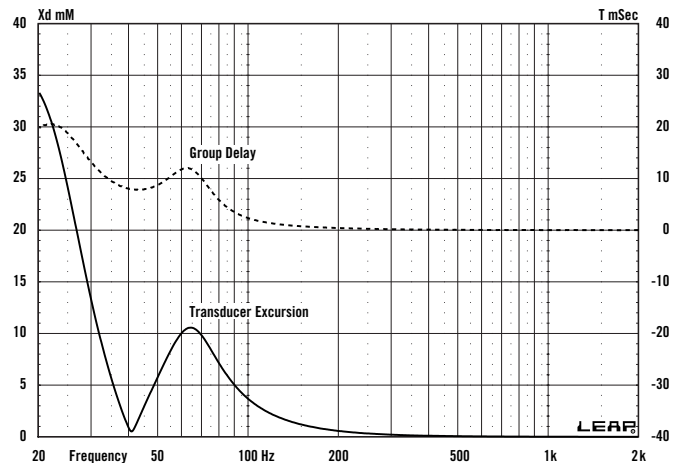

SEALED BANDPASS BOX VOLUME

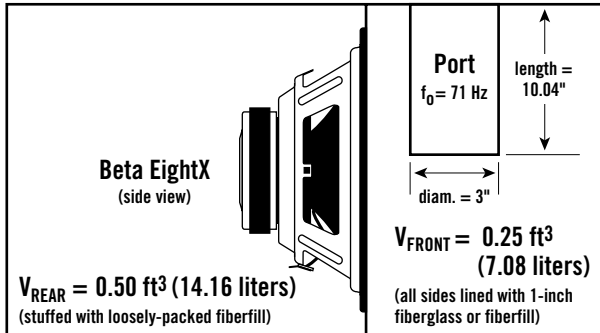

NOTES

SEALED BANDPASS FREQUENCY RESPONSE @ 2.83 V

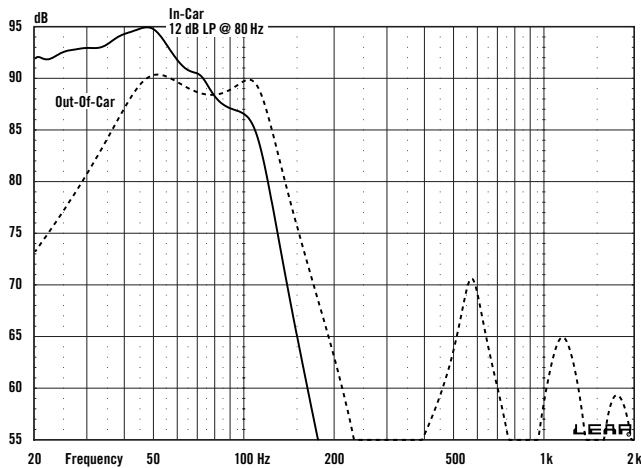

SEALED BANDPASS EXCURSION/GROUP DELAY @ 150 W

